

Series AP5201

DC Strain Gage In-Line Amplifier



Description

The Series AP5201 In-Line Amplifier is a low cost, easy-to-use, general-purpose single-channel conditioner designed for input of pressure, force, torque, weight, and other variables measured by conventional DC-excited strain gage transducers. It is ideal for applications where the transducer is exposed to conditions of high temperature, high humidity, or corrosiveness and where the signal conditioning can be placed in-line and removed from the transducer's environment. Advanced analog design solves the problem of measurement inaccuracy in environments with high electromechanical noise. The AP5201 provides filtered analog output of $\pm 5\text{Vdc}$, $\pm 10\text{Vdc}$, or 4-20 mA; switch selectable by the user. Zero and span adjustments are made through coarse rotary switches and potentiometers. This in-line amplifier will accommodate a wide range of full bridge DC strain gage sensors with bridge resistance for 120 to 10K Ohm. The AP5201 is an excellent complement to STI's mV/V miniature and subminiature load cells/force sensors and miniature pressure transducers. The AP5201 signal conditioner housing is available in a DIN-rail configuration as the Series AP5103.

Standard Features

- Filtered Analog Outputs: ± 0 to 5 Vdc, ± 0 to 10 Vdc, 4-20 mA
- Accepts Standard Full Strain Gage Bridges of 120 Ω to 10K Ω
- User Friendly DIP Switch Settings for Mode, Volts, Current, Filter, Excitation, Zero
- Wide Zero & Span Adjustment
- Wide Input Power Range of 11 – 28 Vdc $\pm 10\%$, 100 mA max
- Field Selectable Bridge Excitation: 2.5 Vdc or 5.0 Vdc
- Switch-Based Shunt Calibration
- Power Status Indicator
- Rugged ABS Flame Retardant Housing

AP5201

Series AP5201 Specifications

Baseline Configuration Specs Represented.
Modifications Encouraged - See Below
Custom Designs Available

Performance

Transducer Types

Conventional 4-arm strain gage bridges, 120 ohm to 10k ohm; zero range is 100% of the stated full scale; a screw terminal is provided for user-supplied shunt calibration resistor (see diagram, below, for typical cabling).

Input Ranges (Nominal, Full-Scale)

.5 to 5 mv/V or 1 to 10 mv/V via internal switch settings.

Switch Settings

- Mode:** Analog Output selection, Vdc or Ima.
- Volts:** Full Scale Output +/- 5 or +/- 10 Vdc.
- Current:** Analog Output 4-20 or 4-12-20 ma.
- Filter:** 3-Pole filter at 200 Hz or 5 KHz @ -3dB.
- Filter:** 3-Pole filter at 200 Hz or 10 Hz @ -3dB.
- Exc:** Excitation voltage 2.5 or 5.0 Vdc.
- Zero:** Expanded adjustment for zero authority.

Calibration

To calibrate, use either the "deadweight" or "shunt" method. Through the use of internal switch controls, the user will specify the mV/V range desired and adjust the fine and coarse controls to achieve the desired analog output, ± 5 or ± 10 VDC or 4-20 ma full-scale. Zero-ing of the sensor is achieved in the same manner with the coarse and fine controls which will adjust the zero position +/- 100%.

Mechanical Characteristics

Housing

ABS UL94VO Flame Retardant case; mountable to panel, or fixture with HEYCO part number M4806 cordgrips; min. cable O.D.=0.105"/max. cable O.D.=0.312". IP64. (See STI Series AP5103 for DIN rail version.)

Environmental Characteristics

Operating Temperature Range

14° F to 158° F.

Operating Relative Humidity

5% to 95%, noncondensing.

Electrical Characteristics

Power Requirements

11- 28 VDC $\pm 10\%$; 100 mA max.

Common-Mode Range

0 to 3 V.

Common-Mode Rejection Ratio (at @1/2 Excitation)

-60 dB.

Input Impedance (Differential and Common-Mode)

>10,000 megohm.

Offset

Adjustable; vs. temperature: $\pm 0.10 \mu\text{V}/^\circ\text{C}$; vs. time: $\pm 5 \mu\text{V}/\text{month}$.

Gain Accuracy

Limited only by calibration accuracy.

Gain Stability

vs. temperature: $\pm 30 \text{ ppm}/^\circ\text{C}$; vs. time: $\pm 10 \text{ ppm}/\text{month}$.

Transducer Excitation

Nominal 2.50 VDC up to 70 mA or 5.00 VDC up to 70 mA. Selectable via internal switch setting.

Analog Filters

10, 200, or 5000 Hz, switch selectable.

Dimensions (inches)

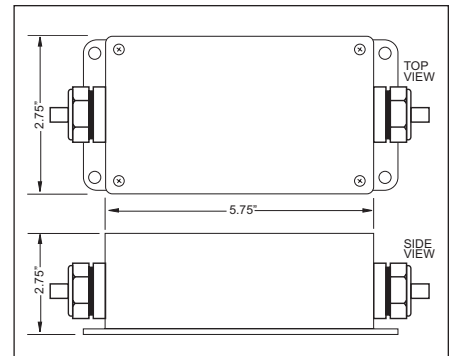

Electrical Characteristics

Analog Outputs

Filtered ± 0 to 5 Vdc or ± 0 to 10 Vdc or 4-20 mA (sourcing). Mode is switch selectable with linearity maintained for 20% overrange (in voltage mode only).

Shunt Enable

Activates shunt when taken to power common potential; ± 25 V without damage; internal pull-up nominal 5 k Ω ; input assume Logic 1 state in the absence of connection.

Power Status Indicator

Green; indicates module power input.

Connection and Adjustment

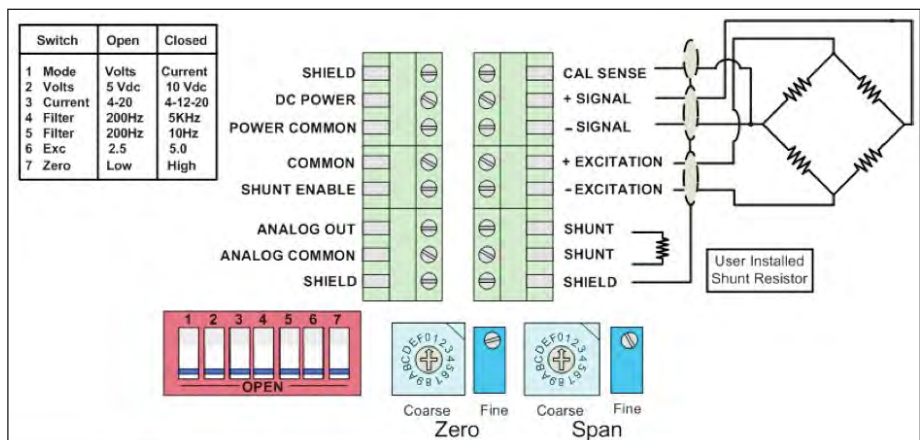

Find More Information at:
stellartech.com

Due to the nature of technology, changes are inevitable. For latest technical specifications, see our website.